

(No Model.)

3 Sheets—Sheet 1.

S. J. SHIMER.
CUTTER HEAD.

No. 547,298.

Patented Oct. 1, 1895.

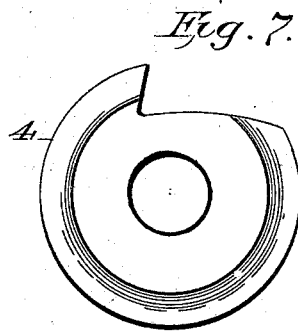
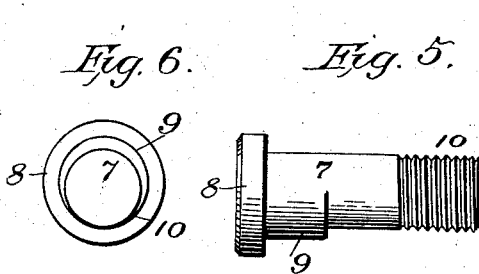
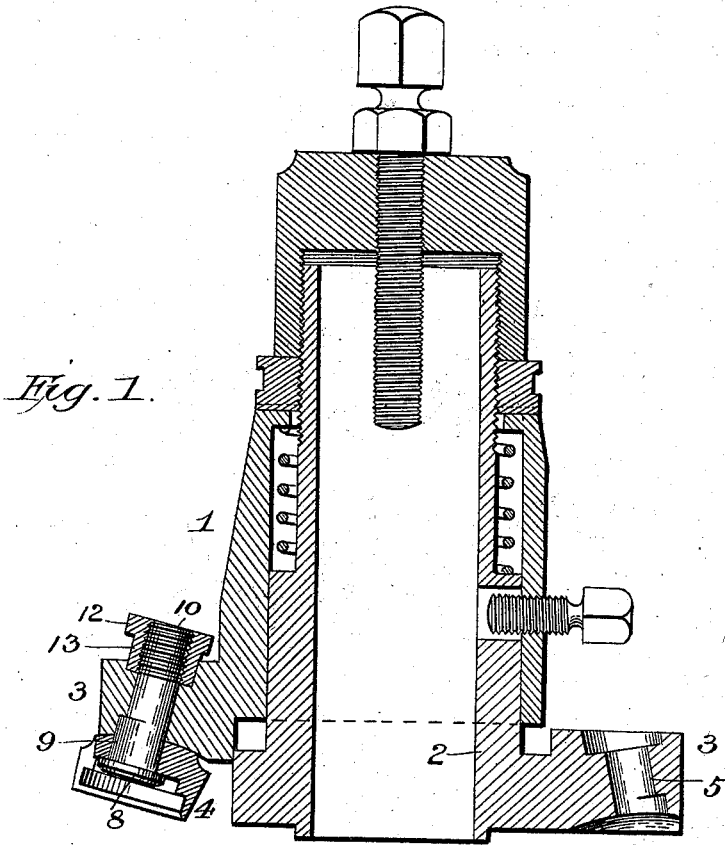

Witnesses:
H. L. Ourand
W. L. Coombs

Inventor:
Samuel J. Shimer
Y Lewis Rogers & Co
Attorneys.

(No Model.)

3 Sheets—Sheet 2.

S. J. SHIMER.
CUTTER HEAD.

No. 547,298.

Patented Oct. 1, 1895.

Fig. 2.

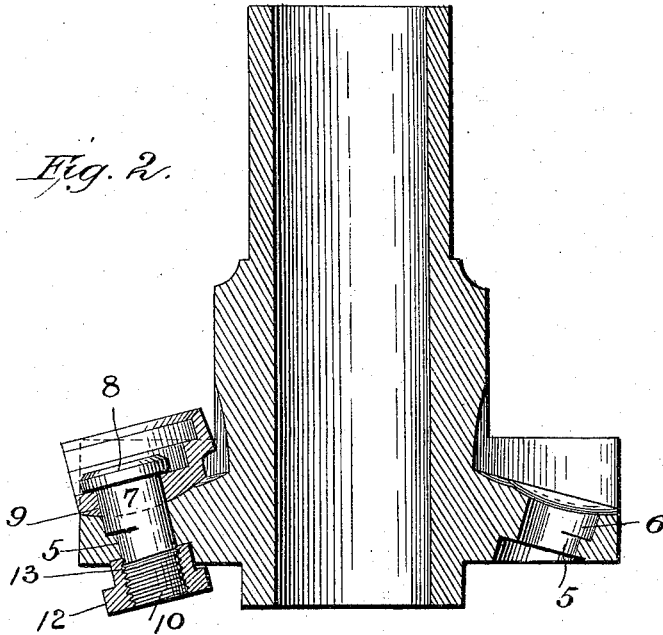

Fig. 8.

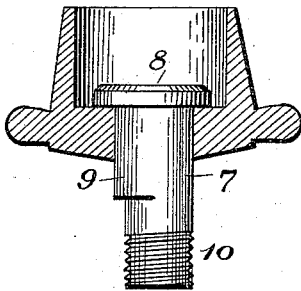
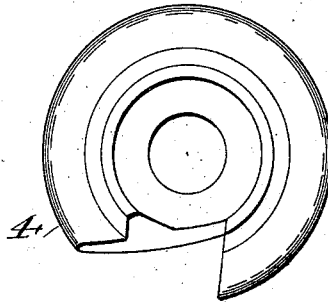

Fig. 9.



Witnesses:
F. L. Curand
W. S. Coombs

Inventor:
Samuel J. Shimer,
by Lewis Duggan & Co.,
Attorneys

(No Model.)

3 Sheets—Sheet 3.

S. J. SHIMER,
CUTTER HEAD.

No. 547,298.

Patented Oct. 1, 1895.

Fig. 3.

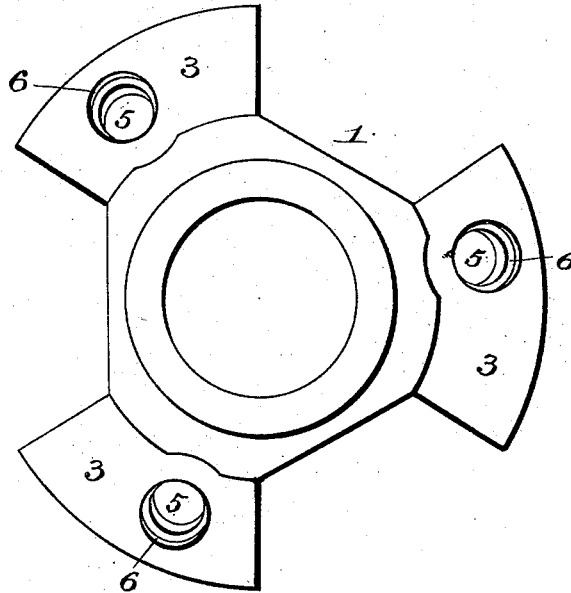
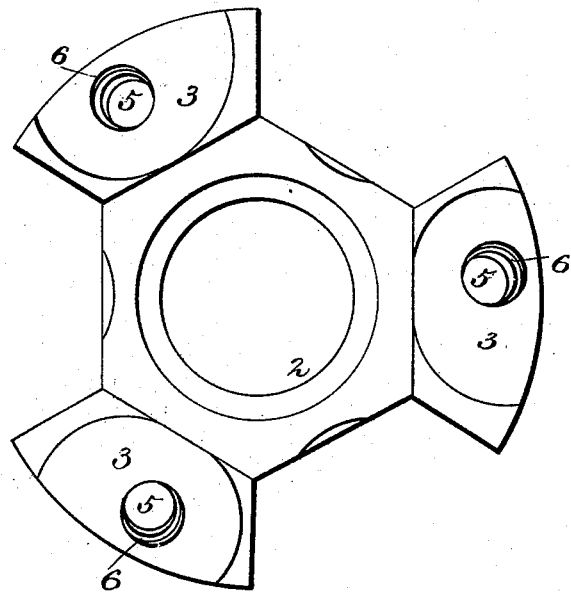

Fig. 4.



Witnesses:
F. L. Ourand,
W. L. Coombs

Inventor:
Samuel J. Shimer,
Wm. Lewis Patten & Co.
Attorneys.

UNITED STATES PATENT OFFICE.

SAMUEL J. SHIMER, OF MILTON, PENNSYLVANIA.

CUTTER-HEAD.

SPECIFICATION forming part of Letters Patent No. 547,298, dated October 1, 1895.

Application filed May 22, 1895. Serial No. 550,221. (No model.)

To all whom it may concern:

Be it known that I, SAMUEL J. SHIMER, a citizen of the United States, and a resident of Milton, in the county of Northumberland and State of Pennsylvania, have invented certain new and useful Improvements in Cutter-Heads; and I do hereby declare that the following is a full, clear, and exact description of the invention, which will enable others skilled in the art to which it appertains to make and use the same, reference being had to the accompanying drawings, which form a part of this specification.

My invention relates to improvements in cutter-heads for woodworking machinery—such, for instance, as matching and molding machines—and its object is to provide improved means for preventing rotation of the bolts which hold the cutters or bits in place, the construction being such that the latter will be clamped between two fixed or stationary surfaces.

The invention is applicable either to what are known as “expansion heads,” which are made in two sections, carrying, respectively, the upper and lower bits, or two solid heads made in a single piece with the cutters alternately arranged on the upper or lower sides thereof, the bits being expanded, if desired, by washers interposed between the bits and their seats.

The invention consists in the novel construction and combination of parts hereinafter fully described and claimed.

In the accompanying drawings, Figure 1 is a longitudinal sectional view of a two-part or expansion cutter-head, showing my improvements applied thereto, one of the bits and its bolts being removed. Fig. 2 is a similar view of a solid head with my improved means of clamping and securing the bits in place. Fig. 3 is a plan view of the upper section of the cutter-head shown in Fig. 1, the bolts and bits being removed. Fig. 4 is a bottom view of the lower section. Fig. 5 is an elevation of one of the clamping-bolts. Fig. 6 is a bottom view of the same. Fig. 7 is a bottom view of one of the bits. Fig. 8 is a sectional view of the same with the bolt in place. Fig. 9 is a plan view of the bit, the bolt being removed.

Referring now to Fig. 1, the reference-numeral 1 designates the upper section of the

head, and 2 the lower section thereof, and formed with flanges 3, having concaved seats for receiving the correspondingly-formed or conical bottoms or middle portions of the bits 4. The lower section is also formed with similar flanges 3, alternately arranged with respect to the flanges of the upper section. This form of cutter-head is fully shown and described in the Letters Patent granted to me October 9, 1894, No. 527,090, and a detailed description, except as to the means for securing the bolts in place, which is the essential feature of the present invention, is not necessary.

In Fig. 2 there is shown a solid cutter-head having a single flange formed with a series of alternating recesses on opposite sides, with inclined and concaved bit-seats to receive the inclined and conical bottoms or inner faces of the bits. The construction of this cutter-head is fully disclosed in the Letters Patent granted to me April 28, 1891, No. 451,311. The bits in this form of cutter-head can be expanded by loosening the nuts on the bolts and slipping in washers between the bits and their seats. The invention is applicable generally to all kind and description of cutter-heads. The bit-seats may be flat, inclined, or concave, and the bolt-holes and bolts may be vertical or inclined.

Referring now to both Figs. 1 and 2, the flange or flanges or that portion of the cutter-head which carries the bits or cutters is formed with a small circular or cylindrical bolt-hole 5 and a larger intersecting hole 6, extending from the seat-face side of the flange inwardly. This hole 6 is also cylindrical or circular, but is eccentric to the hole 5. The smaller hole is within the circle of the larger hole and in line with the inward limit thereof and toward the center of the head, so that the nut of the holding or clamping bolt may take position on the opposite face of the head-flange farther away from the passing lumber and where it is less liable to become loosened.

The reference-numeral 7 designates the clamping-bolt comprising the head 8, cylindrical portion 9, adjoining the same, and the screw-threaded portion or stud 10, which is eccentric to the portion 9. It will be seen by reference to Figs. 5 and 6 that the smaller cylindrical portion of the bolt lies within the

circumference of the larger cylindrical portion, and that part of the periphery of the smaller portion farthest away from the center of the larger portion is in line or flush
 5 with the larger portion or bulge, and a shoulder being formed on the opposite side at the junction with the two portions. It will be seen that the shoulder does not entirely surround the screw-threaded stud or shank, so
 10 that the peripheries of the head and shank opposite the shoulder are in the same plane.

The numeral 12 designates the nut which fits on the screw-threaded end of the bolt and holds the same in place. It is preferably
 15 formed with an angular head adapted to be engaged by a wrench for turning the same and with a cylindrical boss 13, which fits into a corresponding inclined recess in the head flange, so as to have a broad bearing. In
 20 heads where the bolts are vertical, instead of being inclined, the recess is not necessary.

In using the invention the bits are seated in their seats and the bolts passed through the apertures therein and through the bolt-
 25 holes in the flanges, the smaller portion of the bolt fitting in the smaller hole and the larger eccentric portion fitting in the larger hole. The nut is then applied and screwed home. By this construction the bit is clamped
 30 between two fixed parts—viz., the flange and the bolt-head—the bolt being prevented from rotating by reason of the smaller and larger

portions of the same, and the corresponding holes having different centers.

The bolts can be readily turned in any ordinary lathe, as the large and small portions are cylindrical, and the bolt-holes being of a corresponding shape can be made by the usual boring-machines. They will also require no finishing after coming from the machines, as
 40 is the case when concentric bolts and bolt-holes are employed.

Having thus fully described my invention, what I claim is—

As an improved article, a cutter head the
 45 flange of which is formed with a large hole and a small intersecting hole eccentric thereto and within the circle of the larger hole and those portions of the holes nearest the center of the head being in the same planes, a correspondingly shaped securing bolt fitted to
 50 said hole and having its eccentric cylindrical portion projecting beyond the same, whereby its center is located outside of the axial line of the main body of the bolt, substantially as
 55 described.

In testimony that I claim the foregoing as my own I have hereunto affixed my signature in presence of two witnesses.

SAMUEL J. SHIMER.

Witnesses:

THEO. MUNGEN,
 JOS. L. COOMBS.